

**POW-R-BLOK™**  
**Single SCR Isolated Module**  
**430 Amperes / 1800-2200 Volts**

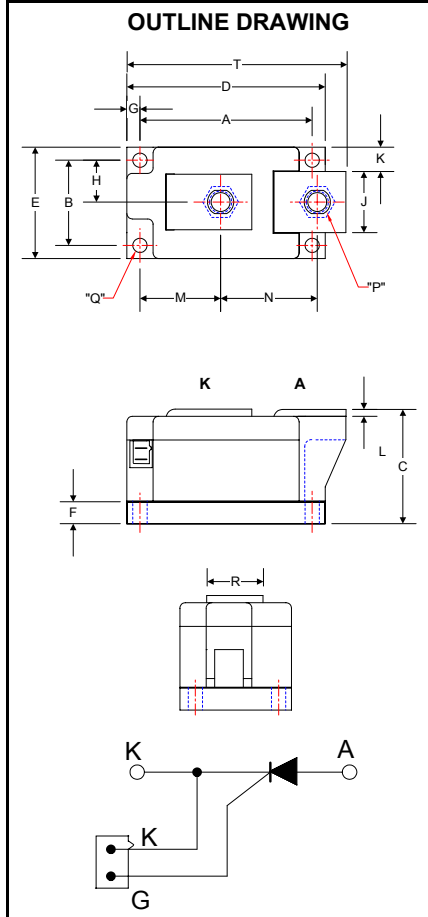

**LS43\_43**  
**Single SCR**  
**POW-R-BLOK™ Module**  
 430 Amperes / 1800-2200 Volts

**LS43 Outline Dimensions**

Dimension	Inches	Millimeters
A	3.15	80.0
B	1.50	38.0
C	2.05	52.1
D	3.62	92.0
E	1.97	50.0
F	0.39	9.9
G	0.24	6.1
H	0.75	19.0
J	0.99	25.1
K	0.48	12.2
L	0.12	3.1
M	1.45	36.8
N	1.76	44.7
P	M10 Metric	M10
Q	0.250 Dia.	6.35 Dia.
R	0.99	25.1
S	0.110 x .032	2.5 x 0.8

Note: Dimensions are for reference only.

**Ordering Information:**

Select the complete eight-digit module part number from the table below.

Example: LS432243 is a 2200 Volt, 430 Ampere Single SCR Isolated POW-R-BLOK™ Module

Type	Voltage Volts (x100)	Current Amperes (x10)
LS43	18 20 22	43

**Description:**

Powerex Single SCR Modules are designed for use in applications requiring rectification and isolated packaging. The modules are isolated for easy mounting with other components on a common heatsink. POW-R-BLOK™ has been tested and recognized by the Underwriters Laboratories.

**Features:**

- Electrically Isolated Heatsinking
- Aluminum Nitride Insulator
- Compression Bonded Elements
- Metal Baseplate
- Low Thermal Impedance for Improved Current Capability
- Quick Connect Gate Terminal with Provision for Keyed Mating Plug
- UL Recognized

**Benefits:**

- No Additional Insulation Components Required
- Easy Installation
- No Clamping Components Required
- Reduce Engineering Time

**Applications:**

- Bridge Circuits
- AC & DC Motor Drives
- Battery Supplies
- Power Supplies
- Large IGBT Circuit Front Ends

**Absolute Maximum Ratings**

Characteristics	Conditions	Symbol	Units
Repetitive Peak Forward and Reverse Blocking Voltage		$V_{DRM}$ & $V_{RRM}$	up to 2200 V
Non-Repetitive Peak Blocking Voltage ( $t < 5$ msec)		$V_{RSM}$	$V_{RRM} + 100$ V
RMS Forward Current	180° Conduction, $T_C=70^\circ\text{C}$	$I_{T(RMS)}$	800 A
Average Forward Current	180° Conduction, $T_C=80^\circ\text{C}$	$I_{T(AV)}$	430 A
	180° Conduction, $T_C=70^\circ\text{C}$	$I_{T(AV)}$	510 A
Peak One Cycle Surge Current, Non-Repetitive	60 Hz, 100% $V_{RRM}$ reapplied, $T_j=25^\circ\text{C}$	$I_{TSM}$	14,000 A
	60 Hz, No $V_{RRM}$ reapplied, $T_j=25^\circ\text{C}$	$I_{TSM}$	16,000 A
	60 Hz, 100% $V_{RRM}$ reapplied, $T_j=125^\circ\text{C}$	$I_{TSM}$	12,000 A
	60 Hz, No $V_{RRM}$ reapplied, $T_j=125^\circ\text{C}$	$I_{TSM}$	14,000 A
	50 Hz, 100% $V_{RRM}$ reapplied, $T_j=25^\circ\text{C}$	$I_{TSM}$	12,000 A
	50 Hz, No $V_{RRM}$ reapplied, $T_j=25^\circ\text{C}$	$I_{TSM}$	14,000 A
	50 Hz, 100% $V_{RRM}$ reapplied, $T_j=125^\circ\text{C}$	$I_{TSM}$	10,000 A
	50 Hz, No $V_{RRM}$ reapplied, $T_j=125^\circ\text{C}$	$I_{TSM}$	12,000 A
Peak Three Cycle Surge Current, Non-Repetitive	60 Hz, 100% $V_{RRM}$ reapplied	$I_{TSM}$	8,600 A
Peak Ten Cycle Surge Current, Non-Repetitive	60 Hz, 100% $V_{RRM}$ reapplied	$I_{TSM}$	7,500 A
$I^2t$ for Fusing for One Cycle	8.3 milliseconds, $T_j=25^\circ\text{C}$	$I^2t$	$1.07 \times 10^6$ A <sup>2</sup> sec
	8.3 milliseconds, $T_j=125^\circ\text{C}$	$I^2t$	$0.82 \times 10^6$ A <sup>2</sup> sec
	10 milliseconds, $T_j=25^\circ\text{C}$	$I^2t$	$0.98 \times 10^6$ A <sup>2</sup> sec
	10 milliseconds, $T_j=125^\circ\text{C}$	$I^2t$	$0.72 \times 10^6$ A <sup>2</sup> sec
Maximum Rate-of-Rise of On-State Current, (Repetitive)	Per JEDEC Standard 397 5.2.2.6	$di/dt$	200 A/ $\mu$ s
Operating Temperature		$T_J$	-40 to +130 °C
Storage Temperature		$T_{stg}$	-40 to +150 °C
Max. Mounting Torque, M6 Mounting Screw			55 in. – Lb.
			6 Nm
Max. Mounting Torque, M10 Terminal Screw			110 in. – Lb.
			12 Nm
Module Weight, Typical			816 g
			1.80 lb
V Isolation @ 25C		$V_{rms}$	3000 V

**Electrical Characteristics,  $T_J=25^\circ\text{C}$  unless otherwise specified**

Characteristics	Symbol	Test Conditions	Min.	Max.	Units
Repetitive Peak Forward Leakage Current	$I_{DRM}$	Up to 2200V, $T_J=125^\circ\text{C}$		80	mA
Repetitive Peak Reverse Leakage Current	$I_{RRM}$	Up to 2200V, $T_J=125^\circ\text{C}$		80	mA
Peak On-State Voltage	$V_{FM}$	$I_{TM}=1500\text{A}$		1.77	V
Threshold Voltage, Low-level	$V_{(TO)1}$	$T_J = 130^\circ\text{C}$ , $I = 15\%I_{T(AV)}$ to $\pi I_{T(AV)}$		0.88	V
Slope Resistance, Low-level	$r_{T1}$			0.66	$\text{m}\Omega$
Threshold Voltage, High-level	$V_{(TO)2}$	$T_J = 130^\circ\text{C}$ , $I = \pi I_{T(AV)}$ to $I_{TSM}$		1.34	V
Slope Resistance, High-level	$r_{T2}$			0.32	$\text{m}\Omega$
$V_{TM}$ Coefficients, Full Range		$T_J = 130^\circ\text{C}$ , $I = 10\text{A}$ to $6\text{kA}$	A =	0.766	
			B =	-1.046 E-02	
		$V_{TM} = A + B \ln I + C I + D \text{Sqrt } I$	C =	1.805 E-05	
			D =	2.00 E-02	
Minimum $dV/dt$	$dV/dt$	Exponential to $V_{DRM}$ $T_J=130^\circ\text{C}$ , Gate Open	1000 Typ.		V/ $\mu\text{s}$
Gate Trigger Current	$I_{GT}$	$T_J=25^\circ\text{C}$ , $V_D=12\text{V}$		200	mA
Gate Trigger Voltage	$V_{GT}$	$T_J=25^\circ\text{C}$ , $V_D=12\text{V}$		3.0	Volts
Non-Triggering Gate Voltage	$V_{GDM}$	$T_J=130^\circ\text{C}$ , $V_D = \frac{1}{2} V_{DRM}$		0.25	Volts
Peak Forward Gate Current	$I_{GTM}$			4.0	Amp
Peak Reverse Gate Voltage	$V_{GRM}$			5	Volts

**Thermal Characteristics**

Characteristics	Symbol		Max.	Units
Thermal Resistance, Junction to Case	$R_{\theta J-C}$	Per Module/Junction	0.0650	$^\circ\text{C/W}$
Thermal Impedance Coefficients	$Z_{\theta J-C}$	$Z_{\theta J-C} = K_1 (1 - \exp(-t/\tau_1))$ $+ K_2 (1 - \exp(-t/\tau_2))$ $+ K_3 (1 - \exp(-t/\tau_3))$ $+ K_4 (1 - \exp(-t/\tau_4))$	$K_1 = 8.03\text{E-}04$ $K_2 = 1.03\text{E-}02$ $K_3 = 1.64\text{E-}02$ $K_4 = 3.75\text{E-}02$	$\tau_1 = 3.39\text{E-}04$ $\tau_2 = 3.15\text{E-}03$ $\tau_3 = 0.106$ $\tau_4 = 2.066$
Thermal Resistance, Case to Sink Lubricated	$R_{\theta C-S}$	Per Module	0.02	$^\circ\text{C/W}$

**Maximum On-State Forward Voltage Drop**  
 (T<sub>J</sub> = 125 °C)

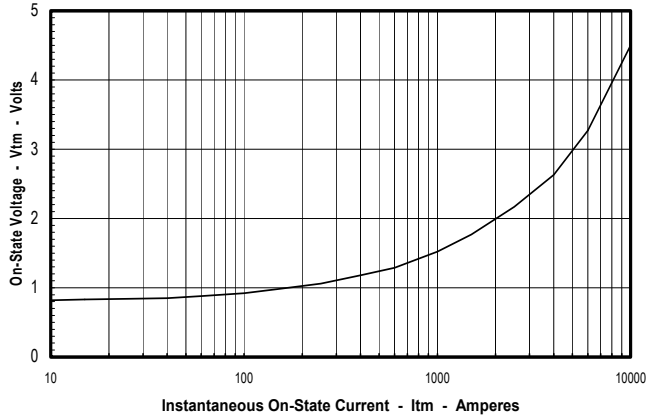

**Maximum Transient Thermal Impedance**  
 (Junction to Case)

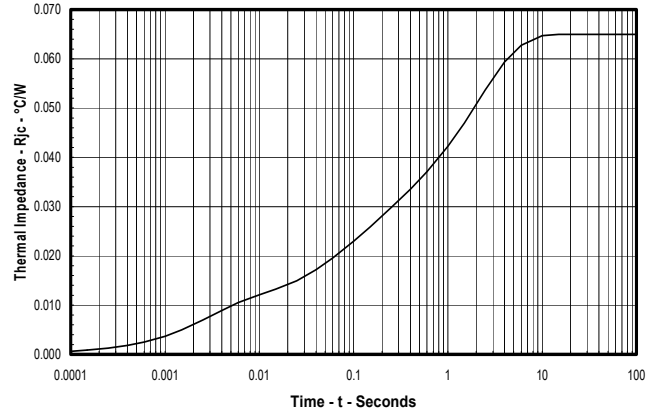

**Maximum On-State Power Dissipation**  
 (Sinusoidal Waveform)

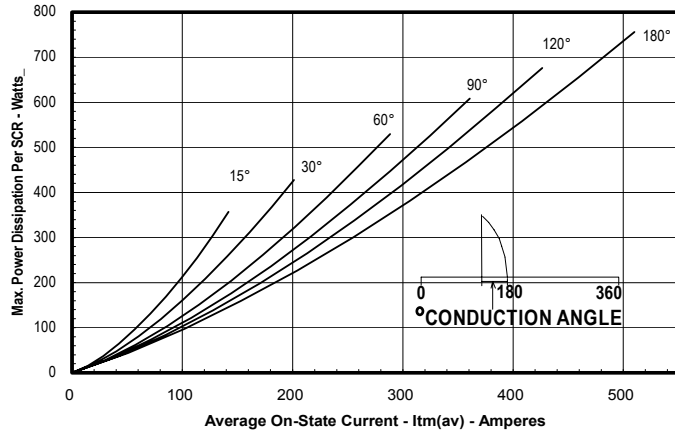

**Maximum Allowable Case Temperature**  
 (Sinusoidal Waveform)

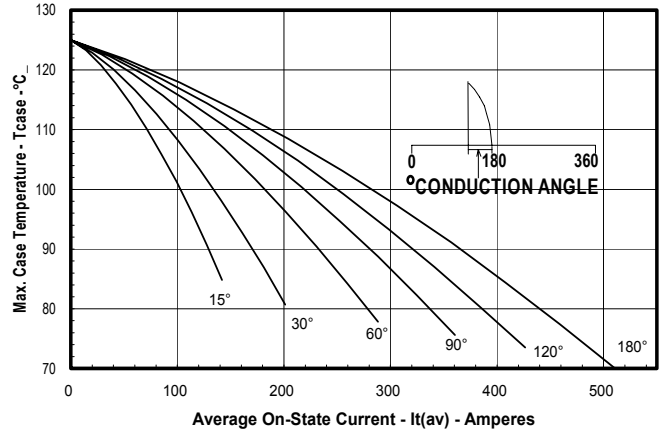

**Maximum On-State Power Dissipation**  
 (Rectangular Waveform)

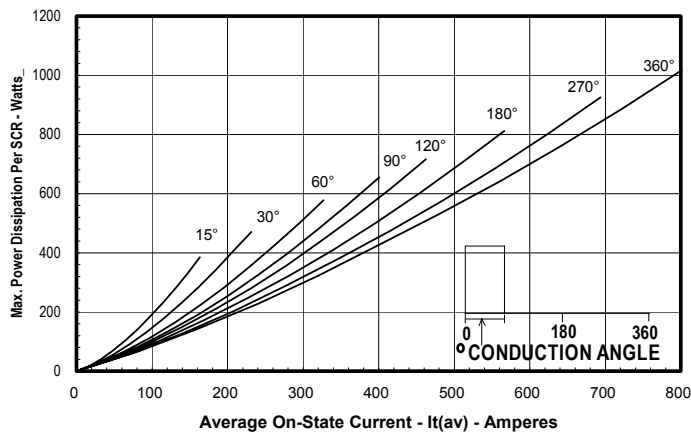

**Maximum Allowable Case Temperature**  
 (Rectangular Waveform)

